

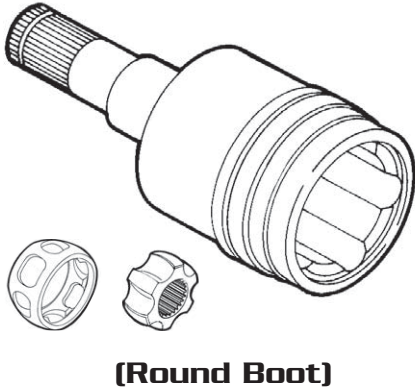

G.M. INBOARD JOINT I.D.

**Double Offset Type
(Round Housing)**



**Tripod Type
(Round Housing)**

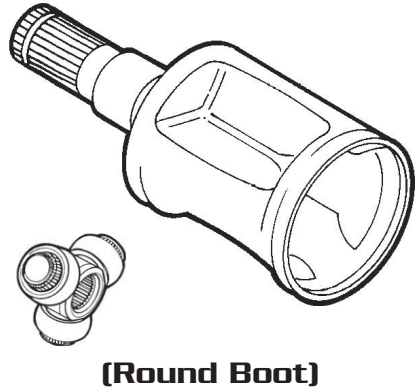

**Tripod Type
("Y" Shaped Housing)**

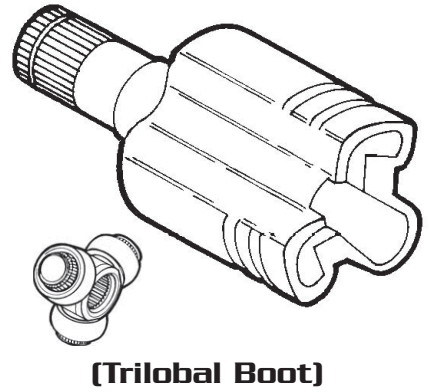

**Cross Groove Type
(Round Housing)**

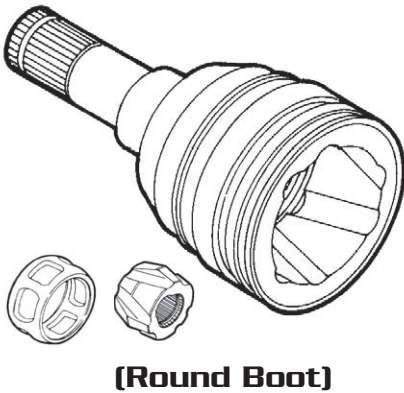

**Flat Roller Type G.M.
(1st Design)**

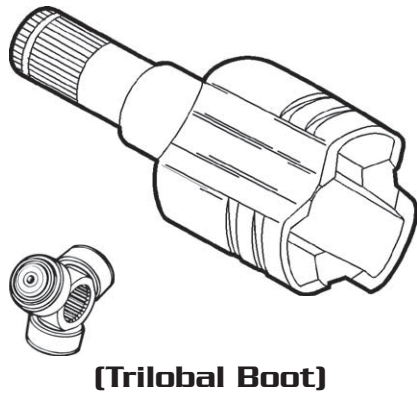

**Flat Roller Type G.M.
(2nd Design)**

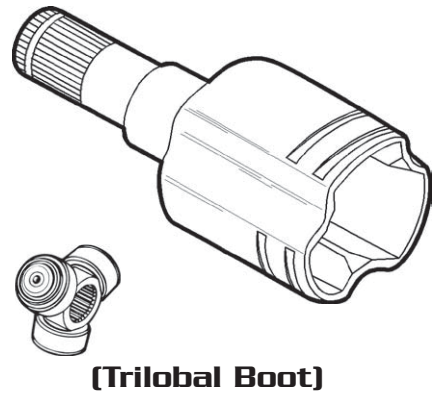

**Square Roller Type G.M.
(1st Design)**

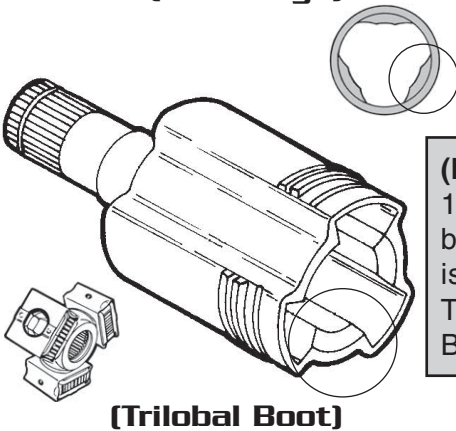

(Note the difference in Contour)
1st Design has shallow depression between Roller Tracks. 2nd Design is a little deeper between Roller Tracks. See page 102 for Trilobal Base Pattern numbers.

**Square Roller Type G.M.
(2nd Design)**

