

THE EMPI ADVANTAGE

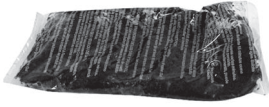

All Joints Assembled with Premium Quality Moly Grease

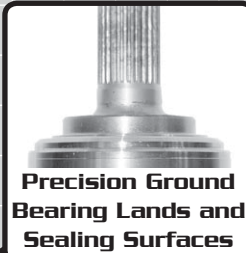

Precision Ground Bearing Lands and Sealing Surfaces



New Cage, Race & C.V. Balls



New Axle Spindle Nuts (Where Applicable)



All New C.V. Boots

THE EMPI ADVANTAGE



Precision Cold Rolled Splines and Threads



New Carrier Bearing and Flange (where required)

ISO/TS 16949:2002
QS 9000
ISO 9002
CERTIFIED FACTORY



New Dust Shields (where required)

All EMPI New Constant Velocity Drive Axles are meticulously assembled with 100% new EMPI produced components throughout.



100% Stainless Steel Boot Clamps



New Tripods



100% Solid Precision Machined Axle Bars



ABS Sensor Rings (where required)



THE EMPI ADVANTAGE

Introducing **EMPI's** line of over **1325** New Constant Velocity Drive Axles. This catalog lists over **2583** specific passenger car, light truck, van, and SUV applications for both foreign and domestic vehicles. **EMPI's** New Drive Axles come packaged in our New **EMPI** Full Color, Tri-lingual (English, Spanish, French) Box. All New Drive Axles are sold per each, (1) per part number.

All New Front Drive Axles start with an "80" prefix and are listed in "Bold" type.
All New Rear Drive Axles start with a "90" prefix and are listed in "Italic" type.

100% New Drive Axles include:

- New C.V. Joints - Inner and Outer
- New C.V. Boots
- New Stainless Steel Boot Clamps
- New Retaining Clip and Hardware (where applicable)
- New Precision Machined & Heat Treated Center Shafts
- New Dust Shields installed (where applicable)
- New Axle Nut (where applicable)
- New ABS Sensor Rings installed (where applicable)
- New Inboard Bearing and/or Flange installed (where applicable)
- Precision ground Bearing Lands and Sealing Surfaces
- New High Temperature / High Pressure Moly Grease
- EMPI Heavy Duty Packaging features New Full Color Graphics, Trilingual language, and Detailed Axle Cut-Away Illustration.

EMPI the Right Axle, the First Time, Every Time!



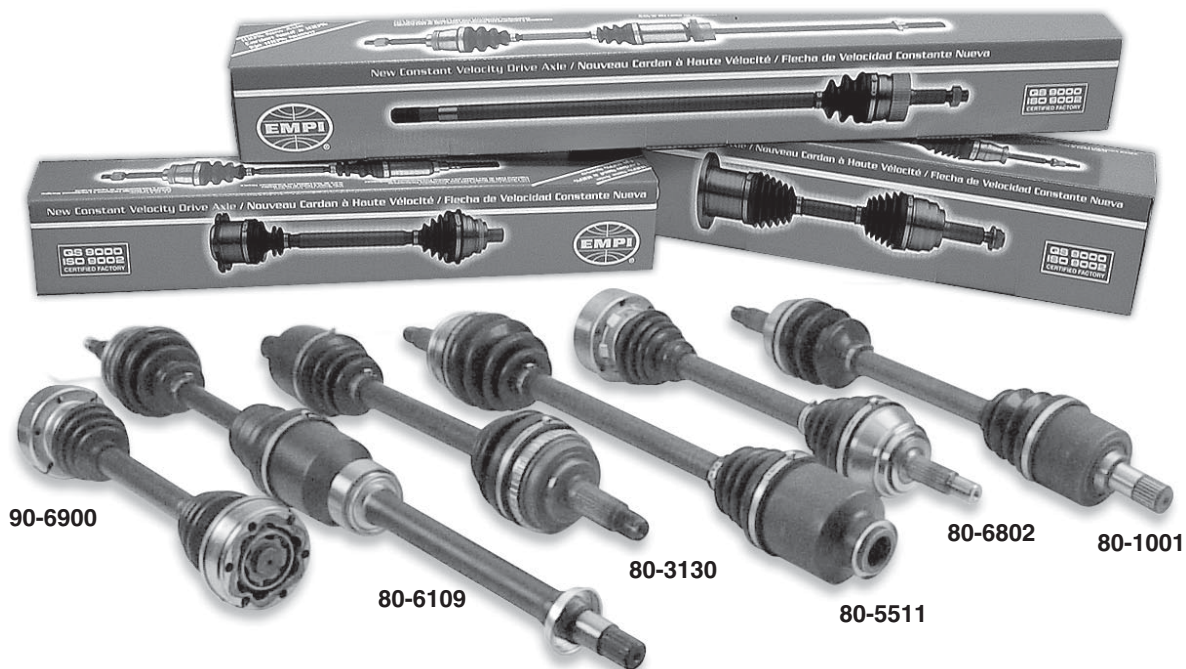

All **EMPI** Axles are engineered for proper fit and function, but it is important to note the following!!

- EMPI** C.V. Joints may be of a different design than Original Equipment.
- EMPI** Axles, in some cases may require that the ABS Ring be removed.
- EMPI** May replace a Trilobal or Thermoplastic Boot with a Round C.V. Boot.
- EMPI** Center Bars are all of the solid design & do not have or require Dampers.
- EMPI** Axles/Joints may have different size threads and nuts than the O.E.



ELECTRONIC MEDIA









Application Cross Reference Part Search Knowledge Center

Year: 2004 Make: AUDI Model: A6 QUATTRO Product: C/V AXLES & BOOTS Engine: V6 3.0L 2976cc

Location	Part Number	Part Type	Qty	Application
REAR INNER	86-1100D	CV Joint Boot Kit	1	
FRONT INNER	86-2188D	CV Joint Boot Kit	1	
FRONT OUTER	86-2281D	CV Joint Boot Kit	1	
REAR OUTER	86-2361D	CV Joint Boot Kit	1	
<input checked="" type="checkbox"/> FRONT LEFT	80-9039	CV Joint Half Shaft	1	AWD, Automatic Trans
<small>Comment: Fr. CH.# 4AW-005-001</small>				
<input checked="" type="checkbox"/> FRONT RIGHT	80-9038	CV Joint Half Shaft	1	AWD, Automatic Trans
<small>Comment: Fr. CH.# 4AW-005-001</small>				

view of
www.showmetheparts.com/empi



80-9038

Overall Compressed Length 20 1/2"

Bolt-On (6 Holes)

45 Windows

38 Splines

www.empius.com now has new features to make part access easier:

- Updated 2011 Premium Drive Axle Catalog in PDF Format.
- Application Guide, Buyers Guide and interchanges are updated monthly.
- Allows look up of detailed photographs of EMPI Drive Axles by entering the EMPI product number or description.
- Includes technical data such as length, ABS and spline details to assist in identification.
- Sign up your email address to be notified immediately when updates are made to the EMPI Web Site.

www.showmetheparts.com/empi

- Brand New Axle On-Line Parts Catalog
- Allows traditional electronic catalog look-up (year, make, model)
- Includes images of axles, buyers guide, and installation instructions (where applicable)
- Updated monthly, so as to have the latest changes at your fingertips!



[Activant Electronic Catalog](#) [Wrenchhead Electronic Catalog](#)